

## Hinges

Zinc die casting / Stainless Steel, extended, horizontally elongated

### SPECIFICATION

#### Types

- Type **A**: 2x2 bores for countersunk screws
- Type **C**: 2x2 threaded studs

#### Version in Zinc die casting ZD

Zinc die casting  
plastic coated  
black, RAL 9005, textured finish **SW**  
silver, RAL 9006, textured finish **SR**

Pin, Stainless Steel AISI 303 (A2)

Threaded stud (type C)  
Stainless Steel AISI 316

#### Version in Stainless Steel (only type A) NI

- AISI CF-8
- matt shot-blasted **GS**

Pin, Stainless Steel AISI 316Ti (A4)



### INFORMATION

Hinges GN 237 with extended hinge wings are made in a compact and sturdy design. They are used when larger spacings are required for the attachment bore holes.

### TECHNICAL INFORMATION

- Stainless Steel characteristics (see page A26)
- Load rating information of hinges (see page A40)
- List of hinges types (see page 1362)

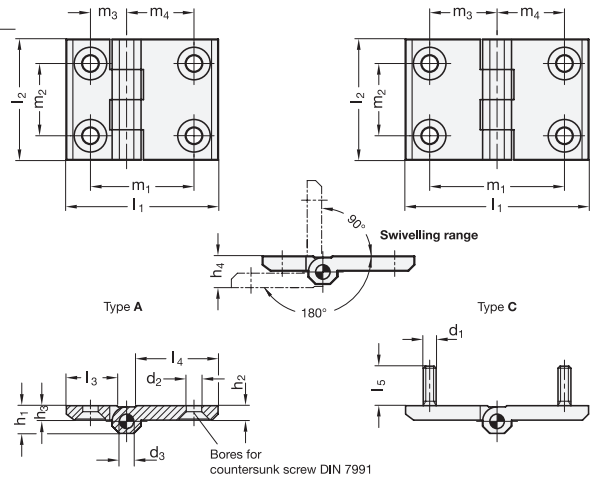

\* Complete with colour index of the Hinges (SW or SR)

**SW** RAL9005    **SR** RAL9006

### GN 237-ZD

Description	l1	l2	d1	d2	d3	h1	h2	h3	h4 +0.5	l3	l4	l5	m1	m2	m3	m4	△
GN 237-ZD-63-50-A-*	63	50	-	6.3	6	11.5	6	6.5	13	18.5	31.5	-	43	30	15	28	100
GN 237-ZD-63-50-C-*	63	50	M 6	-	6	11.5	6	6.5	13	18.5	-	12	43	30	15	28	119
GN 237-ZD-76-50-A-*	76	50	-	6.3	6	11.5	6	6.5	13	31.5	31.5	-	56	30	28	28	130
GN 237-ZD-76-50-C-*	76	50	M 6	-	6	11.5	6	6.5	13	31.5	-	12	56	30	28	28	145
GN 237-ZD-90-60-A-*	90	60	-	8.4	8	15	8	8.5	17	21.5	51.5	-	63	36	18	45	240
GN 237-ZD-90-60-C-*	90	60	M 8	-	8	15	8	8.5	17	21.5	-	14	63	36	18	45	277
GN 237-ZD-120-60-A-*	120	60	-	8.4	8	15	8	8.5	17	51.5	51.5	-	90	36	45	45	313
GN 237-ZD-120-60-C-*	120	60	M 8	-	8	15	8	8.5	17	51.5	-	14	90	36	45	45	364

### GN 237-NI

STAINLESS STEEL

Description	l1	l2	d2	d3	h1	h2	h3	h4 +0.5	l3	l4	m1	m2	m3	m4	△
GN 237-NI-63-50-A-GS	63	50	6.3	6	11.5	6	6.5	13	21	34	43	30	15	28	132
GN 237-NI-76-50-A-GS	76	50	6.3	6	11.5	6	6.5	13	34	34	56	30	28	28	154
GN 237-NI-90-60-A-GS	90	60	8.4	8	15	8	8.5	17	26	56	63	36	18	45	287
GN 237-NI-120-60-A-GS	120	60	8.4	8	15	8	8.5	17	56	56	90	36	45	45	369